



Heat Sealer Prima - 300 mm



Model no.: PLHS-23

Heat Sealer is a consistent tool used to perform sealing on flexible packaging products and other thermoplastic materials using pressure and heat by maintaining high temperatures. PRESTO Heat Sealer is manufactured under various Test Standards such as ASTM F 2029.

- Microprocessor based display for accurate test results
- Highly accurate test results under pneumatic pressure control.
- Single Push button operation after setting PID temperature and time
- Strong heating jaws for performing tests
- No slippage in case specimen is placed uniformly without any loops.
- Bright LED display for temperature and timer
- PID temperature controller for highest level of controls and repeatability
- Digital Preset timer
- EN 31 hard and temper sealing jaw material
- Guide rod mechanism for efficient control of sealing
- Independent adjustment of temperature for upper & lower jaws

Three type of jaws to choose from :

- A. Plain
- B. Diamond Knurled
- C. Straight line

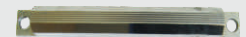

* Any one jaw is in scope of supply

PRESTO Heat sealer is used to measure the heat seal performance of composite films, plastic films such as PP, PE used in packaging different food products such as milk powder, instant noodle, food, washing powder, and drugs.

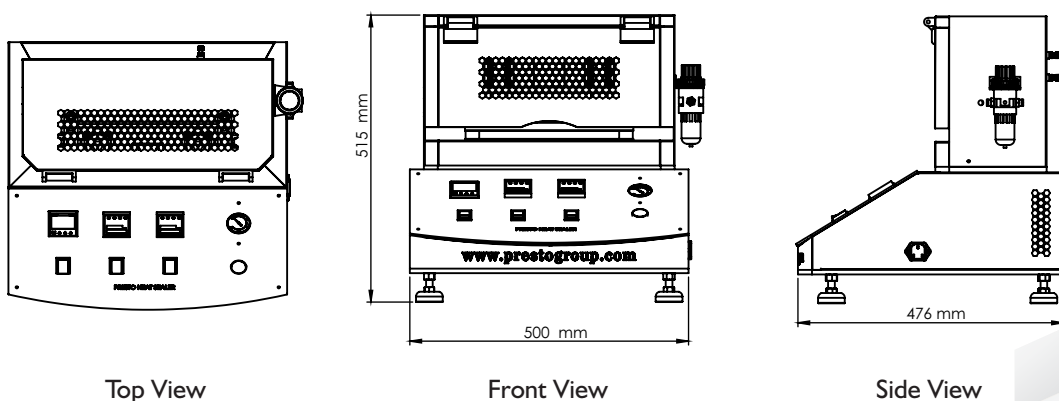



Presto Stantest Pvt. Ltd.

I-42, DLF Industrial Area Phase-1, Delhi Mathura Road, Faridabad 121003, Haryana, India
 P : 9210 903 903, +91 129 4272727, 93111 24302 E : info@prestogroup.com



- Faridabad
- Sonipat
- Kolkata
- Mumbai
- Pune
- Ahmedabad
- Chennai
- Bangalore
- Hyderabad

www.prestogroup.com

Key Specifications:

Equipment Range	Ambient to 350°C
Sealing Temperature Working range	Ambient to 230°C
Accuracy	± 1°C
Least Count/Resolution	0.1°C
Power	220V , Single phase, 50 Hz
Sealing size **	<ul style="list-style-type: none"> • 150x 15 mm OR • 300x 15 mm
Temperature Controller	4 digit PID
Dwell Heat Seal time	0.1 – 99.9 sec
Timer	4 Digit Digital
Heat Sensor	Pt-100, Platinum Resistance Temperature Detector (RTD)
Sealing Pressure	2 - 6 Bar

** Any one size options can be chosen as per requirement

Highlights:

Temperature Controller	PID
Timer	Digital Preset type
Heat Source	Cartridge Heaters
Seal Pattern	Straight line, Plain & Diamond Knurling (select any one pattern)
Test Performed	Heat Seal
Material	Mild Steel
Finish	Powder coated Havel Gray & Blue combination finish and bright chrome / zinc plating for corrosion resistant finish
Dimensions	500 x 476 x 515 mm

* Air Compressor is not part of supply

Other models available :

- 150 mm & 500mm sealing jaws length on request.

Thank you customers for choosing us as your partners in growth !



*All the above logos are the sole property of their respective owners and are used purely for depiction purposes only.

OUR OTHER PRODUCTS :-

Box Compression Tester Digital cum Computerised	Scuff Resistance Tester	Tensile Tester Digital	Spectrocolorimeter	Cobb Sizing Tester	Digital GSM Balance

www.prestogroup.com

