



Torque Tester HMI Motorised (PLUTO Series Computerised)



Model No. PTT - 0102 (C) Touch Screen Pluto Computerised
Registered Design No. 297137

Torque Tester – HMI Touch Screen is a new generation fully automatic Torque tester. It gives Torque in digital format. The HMI display is a high end sophisticated read out with Auto Tare (ZERO) set facility and Peak Hold arrangement. The test sample is placed in between the anti-slip holders/pegs for strong holding of test sample.

- Strong clamping pegs/holders for zero slip gripping support
- Precise measurement of torque
- HMI Colour Display for accuracy and repeatability
- Excellent system control with latest HMI touchscreen
- Program profile for selecting test parameters and performing the test.
- Current test running status display
- Highly accurate test results and calculate the test in average also.
- Fully automatic test after easy settings
- USB option available for storing test data
- Easy to access Inbuilt self-calibration facility
- Applicable for Different sized PET bottles
- Selectable torque unit.

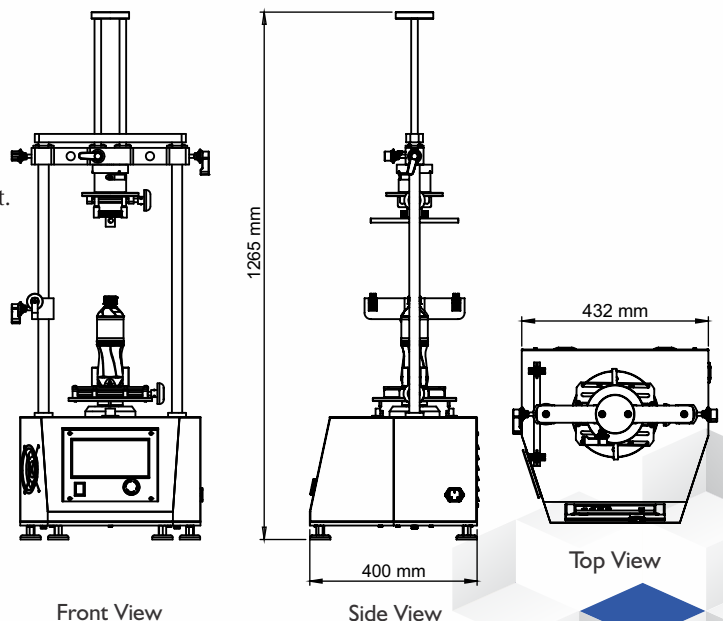



Presto Stantest Pvt. Ltd.

I-42, DLF Industrial Area Phase-1, Delhi Mathura Road, Faridabad 121003, Haryana, India
 P : 9210 903 903, +91 129 4272727, 93111 24302 E : info@prestogroup.com

- Faridabad • Sonipat • Kolkata • Mumbai • Pune • Ahmedabad
- Chennai • Bangalore • Hyderabad

www.prestogroup.com



Key Specifications:

Max. Torque Range	100 lb inch
Accuracy	± 0.50 lb-Inch (with master weight)
Least Count/Resolution	0.01 lb inch
Power	220V, Single phase, 50 Hz
Display	HMI TFT Screen 4.3 Inch
Torque Unit	lb Inch / Nm
Minimum Diameter for specimen holding	20 mm
Maximum Diameter for specimen holding	130 mm
Max.size of test bottles to be tested	2.5 litres
Sample Size	Min. height 25 mm
Anti-vibration pad	Specially designed to reduce the effect of the vibration

Torque Tester is designed to provide accurate and precision based torque value which is not obtained by manual twisting. The instrument is used for testing the opening force of the PET bottles when subjected to a load under twisting.

Highlights:

Safety	Yes (over load protection)
Data Out put (USB)	USB option available for storing test data Time / Date / Torque / Pass / Fail status
Material	Mild Steel
Finish	Powder coated Havel Gray & Blue combination finish and bright chrome / zinc plating for corrosion resistant finish
Dimensions	400x432x1265 mm
Calibration Kit	Inbuilt Calibration fixtures with 10 & 20 Lbs weights

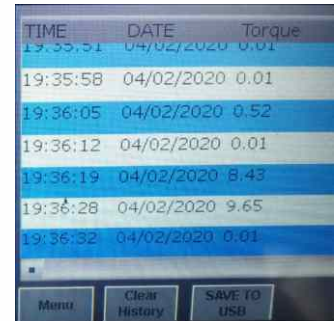

USB Data Report

Optional :

- Digital Torque Tester & Motorised models available in various range on request

Thank you customers for choosing us as your partners in growth !



*All the above logos are the sole property of their respective owners and are used purely for depiction purposes only.

OUR OTHER PRODUCTS :-

