



Color Matching Cabinet Spectrum – I (ASIA)



Model No. Spectrum - I (Asia)

Color Matching Cabinet Spectrum Asia is a consistent tool useful for visual assessment and evaluation of colors. Used in various industries and laboratories to maintain quality and color consistency of a sample to detect the phenomenon of metamerism.

- Standardized and controlled lightening conditions.
- Wide Viewing Area
- High Quality Light sources used.

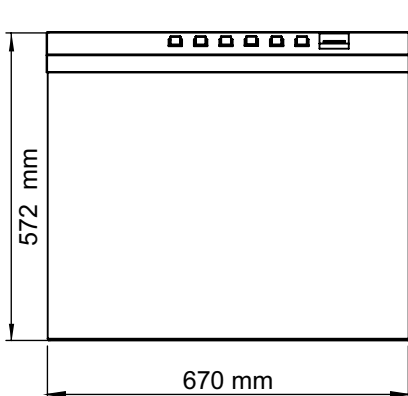

Top View

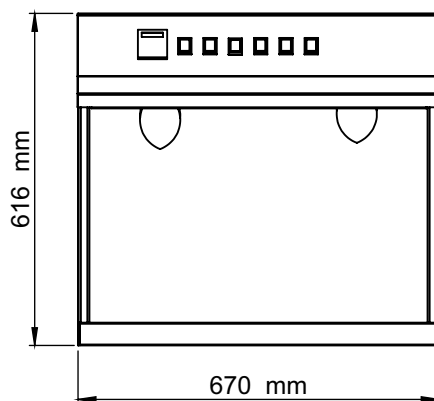

Front View

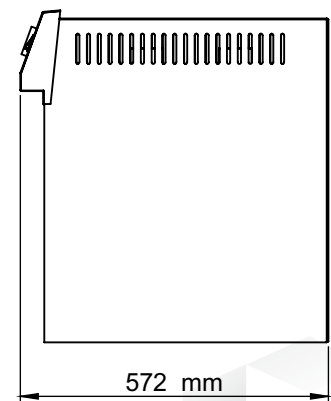

Side View



Presto Stantest Pvt. Ltd.

I-42, DLF Industrial Area Phase-1, Delhi Mathura Road, Faridabad 121003, Haryana, India
P : 9210 903 903, +91 129 4272727, 93111 24302 E : info@prestogroup.com

• Faridabad • Sonipat • Kolkata • Mumbai • Pune • Ahmedabad
• Chennai • Bangalore • Hyderabad

www.prestogroup.com



Key Specifications:

Angle of Viewing Booth	45 Degree
Viewing Booth Material	Wood or Steel
Lights	D 65 Artificial Daylight, TL 84 Triphosphor Fluorescent Light (Point of Sale) UV Black light Ultra Violet Black Light, TFL Tungsten Filament Light, CWF Cool White Light
Time Totalizer accuracy	± 0.2% over entire range
Viewing Area	L 675 x W 455 x H 400 mm
Time Totalizer Least Count	1/10 h
Read out	99999.9 hr.
Size of tube light	2 Feet

Highlights:

No. of D-65 lights	2
No. of CWF lights	1
No. of UV lights	1
No. of TFL lights	4
No. of TL-84 lights	1
Accessories	with sample sporting angle Viewing Booth 45 Degree-1 nos.

- Used in various Industries like paper and packaging, textile etc.
- Comes with 5 light sources as per CIE International Standards.
- Also available in Spectrum USA and Spectrum Europe models.

Thank you customers for choosing us as your partners in growth !



*All the above logos are the sole property of their respective owners and are used purely for depiction purposes only.

OUR OTHER PRODUCTS :-

Box Compression Tester	Scuff Resistance Tester	Tensile Tester Digital	Spectrocolorimeter	Cobb Sizing Tester	Digital GSM Balance

