



Peel Strength Tester



Model No. PPSS-2020 S

Peel Strength Tester is a consistent tool to quantify the permanence of adhesion or peel ability of self-adhesive pressure sensitive materials. PRESTO Peel Adhesion Tester is manufactured under test standard ASTM D 903.

Available in Computerized model also.

- Microprocessor based display for accurate test results
- Display for Peel Adhesive strength of test specimen
- Highly accurate test results under force.
- Strong gripping clamps to perform Peel test at 180°
- Inbuilt calibration facility

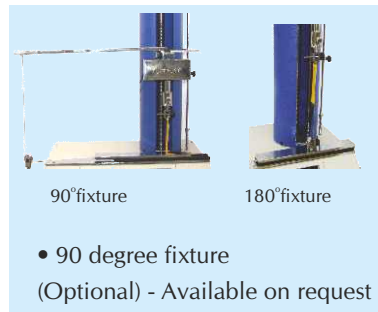

Peel Strength Tester reveals the peeling strength force required to remove pressure sensitive coated material, which has been applied to standard test specimen under specified conditions from the plate at a specified angle and speed.

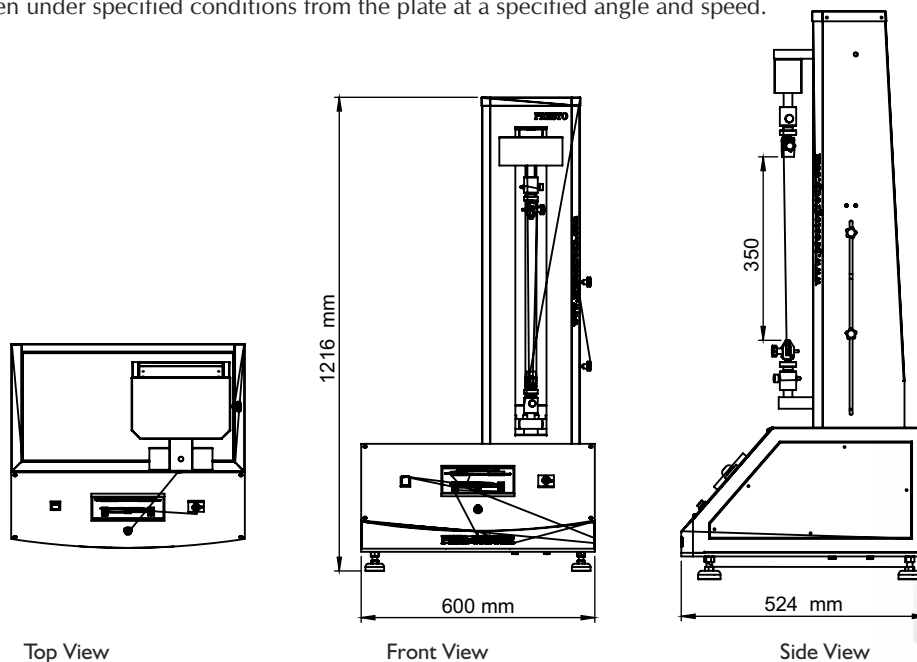



Presto Stantest Pvt. Ltd.

I-42, DLF Industrial Area Phase-1, Delhi Mathura Road, Faridabad 121003, Haryana, India
P : 9210 903 903, +91 129 4272727, 93111 24302 E : info@prestogroup.com



- Faridabad • Sonipat • Kolkata • Mumbai • Pune • Ahmedabad
- Chennai • Bangalore • Hyderabad

www.prestogroup.com

Key Specifications:

Load Cell Capacity	20 Kgf
Display	LED (Digital) 7 segment
Accuracy	± 2% at full load (with master load)
Least Count/Resolution	0.002 Kgf
Power	220V, Single phase, 50 Hz
Test Speed	300 mm/min ± 5%
Memory	After perform the test max. value save in memory
Grip Separation	Min. 25 mm & Max. 350 mm
Anti-vibration pad	Specially designed to reduce the effect of the vibration

Highlights:

Over Load Safety	Yes (over load protection available)
Safety Switch	Yes

The Peel Strength tester measures the peeling strength required to peel of the laminates.

Optional Features :

- Peel Tester Digital cum computerized models and Digital model (with or without printer facility) also available.
- VFD drive multi-speed facility also available (30-300 mm / min.)
- 90 Degree fixture and 180 Degree fixture available on request (Optional)

Thank you customers for choosing us as your partners in growth !



*All the above logos are the sole property of their respective owners and are used purely for depiction purposes only.

OUR OTHER PRODUCTS :-



Head Office :

Presto Stantest Private Limited

I-42, DLF Industrial Area Phase-1, Delhi Mathura Road, Faridabad 121003, Haryana, India

P : +91 129 4272727 (100 Lines) E : info@prestogroup.com

- Faridabad • Kolkata • Mumbai • Pune • Ahmedabad • Chennai • Bangalore

www.prestogroup.com

