



TOP LOAD TESTER - PRIMA SERIES



Model No. PTL 105 (Prima)

Top Load Tester Prima Model is a new generation fully automatic motorized top load tester. It gives Compressive Buckling Load on Human Machine Interface based Touchscreen Display. The display is a high end sophisticated with Auto Tare (ZERO) set facility and Peak Hold arrangement. The test sample is placed in between the inverted jaws for zero slip gripping. Other model available are Top Load Tester –Digital and Computerized.

- HMI Based Touchscreen Model
- Inverted straight plates for zero slip gripping support
- Auto Stop at home position after test completion
- Provision of Cyclic Test
- Microprocessor based for accuracy and repeatability
- Option for user to switch off machine in case of buckling of test sample.
- In-house standalone calibration facility
- Speed Control Sensing mechanism with Sample placement.
- Program profile for programming test parameters and product identification in test report
- Automatic Test and Return Speed Selection.
- Easy Data Management. User can create product identification, user name, etc.
- Graph Test report of Load Vs Deflection
- Data Tabulation in Data Record format.
- USB option available for storing test data
- Data output in Graphical and data record format.
- History Data involves User name, date, time, Deflection etc.

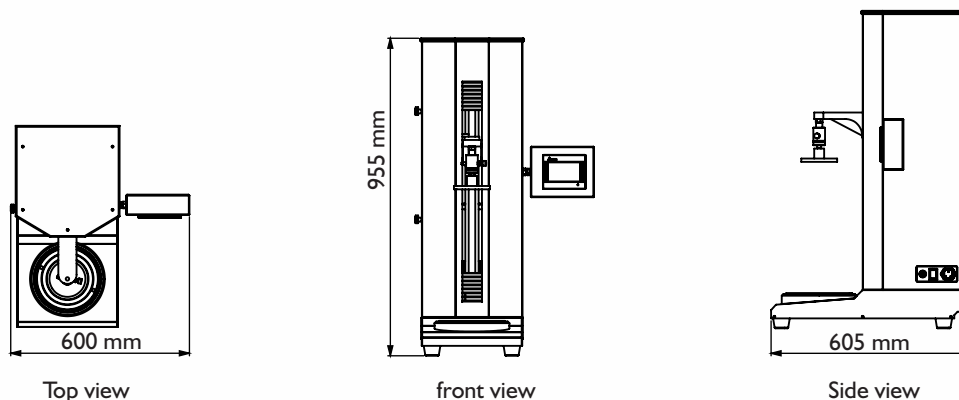



Presto Stantest Pvt. Ltd.

I-42, DLF Industrial Area Phase-1, Delhi Mathura Road, Faridabad 121003, Haryana, India
 P : 9210 903 903, +91 129 4272727, 93111 24302 E : info@prestogroup.com



- Faridabad • Sonapat • Kolkata • Mumbai • Pune • Ahmedabad
- Chennai • Bangalore • Hyderabad

www.prestogroup.com

Top Load Tester is designed to provide Compressive buckling load. The instrument is used for testing the load bearing capacity of the PET containers when subject to an extreme load from the Top direction. It determines accurately the maximum load a PET container can bear without any deformation or failure.

Key Specifications:

Max. Load Range	100 Kgf
Accuracy	± 2% full scale (with master load)
Least Count/Resolution	10gm
Power	220V, Single Phase, 50 Hz
Display	HMI (Touchscreen) TFT LCD Screen 65536 color 480 x 272 pixels Size : 4.3 Inch
Load unit	Kgf
Motor	Imported DC stepper Motor
Sample size	Max. Bottle height 500 mm

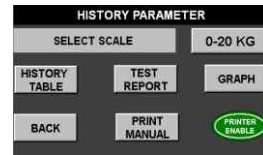

Highlights:

Safety	Upward and Downward Limit switches
Grips	Inverted straight Compression Plates 1 set
Material	Mild Steel
Finish	Power coated Havel Gray & Blue combination finish and bright chrome / zinc plating for corrosion resistant finish
Dimensions	605x600x955 mm

First time in india

Features of the touch screen include :

- 8 function keys
- 4.3" (480x272) TFT LCD 65536 colors.
- Provides USB Host for USB flash drive.
- Supports CF memory card.
- USB 1.1 for high-speed screen data download.
- 480 x 272 pixels IP 65 complaint.
- 128Mb Flash Memory.

Optional Features:

Top Load Tester Computerized Digital/ Digital model also available.

Thank you customers for choosing us as your partners in growth !



*All the above logos are the sole property of their respective owners and are used purely for depiction purposes only.

OUR OTHER PRODUCTS :-



Top Load Tester

Wall Thickness Gauge

Gloss Meter Triangle

Eccentricity Tester

Moisture Analyzer MB 45

Preform Neck Cutter

