

Auto Clave



Model No. PAC- 0123

Autoclave is a consistent tool used to sterilize various medical tools in microbiology labs, pharmaceutical, veterinary science, dentistry, plastics, production lineups etc. PRESTO Autoclave is made of high grade stainless steel material with radial locking system.

- Microprocessor based display for accurate test results
- Highly accurate test results under pressure saturated steam
- Radial Locking system
- High Grade stainless steel construction
- Autocut off Safety Device for temperature & pressure overshoot
- Bright LCD display
- Feather touch controls
- Pressure regulating valve for maintaining pressure inside test chamber

Autoclave is used to create sterilization requiring elevated temperature and pressure different from the ambient air pressure. Additional Options like hysteresis, purging, proportional band available for optimization process.

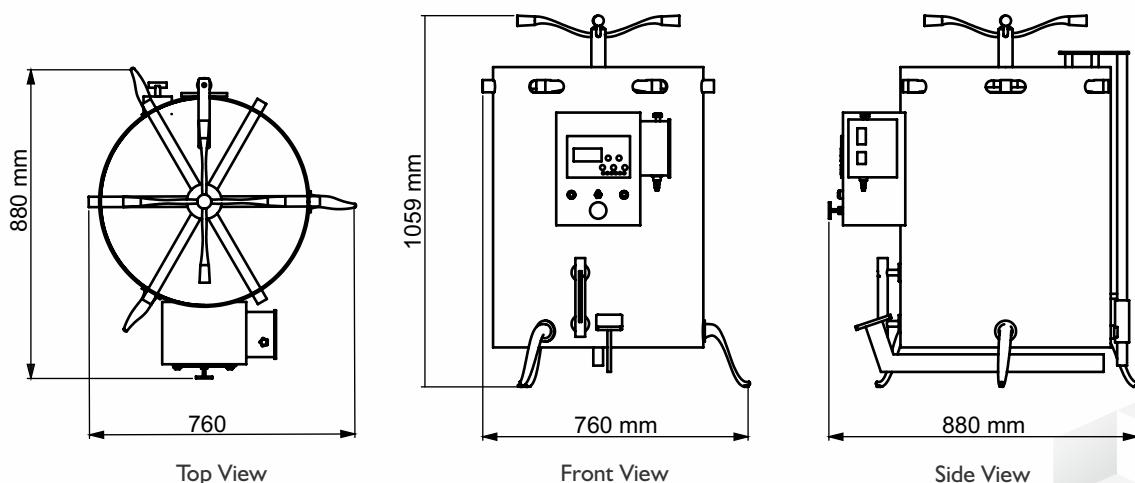

Key Specifications:

Display	LCD (Digital)
Pressure Gauge Range	0-30 psi, 2.1 Kg/cm ²
Timer	Upto 999.9 min
Power	220V , Single phase, 50 Hz
Temperature Range	working range 121°C / Max. 125°C
Test Bucket Size	Internal Dia 12" x Height 17"
Water Requirement	5-8 Ltr.

Highlights:

Settings	Chamber temperature, Sterilization time, Dry time, High Temperature
Auto cutoff Facility	Yes
Material	High Grade Stainless Steel (304 Grade)
Dimensions	760x880x1060 mm
Temperature Control	PID
Water Level Indicator	Yes

Optional Features:

Available in various capacity as per requirement.

Thank you customers for choosing us as your partners in growth !



*All the above logos are the sole property of their respective owners and are used purely for depiction purposes only.

OUR OTHER PRODUCTS :-



Head Office :

Presto Stantest Private Limited

I-42, DLF Industrial Area Phase-1, Delhi Mathura Road, Faridabad 121003, Haryana, India

P : 9210 903 903, +91 129 4272727 E : info@prestogroup.com

• Faridabad • Kolkata • Mumbai • Pune • Ahmedabad • Chennai • Bangalore • Hydrabad

www.prestogroup.com

